

KBC00100 BCD Clock Kit

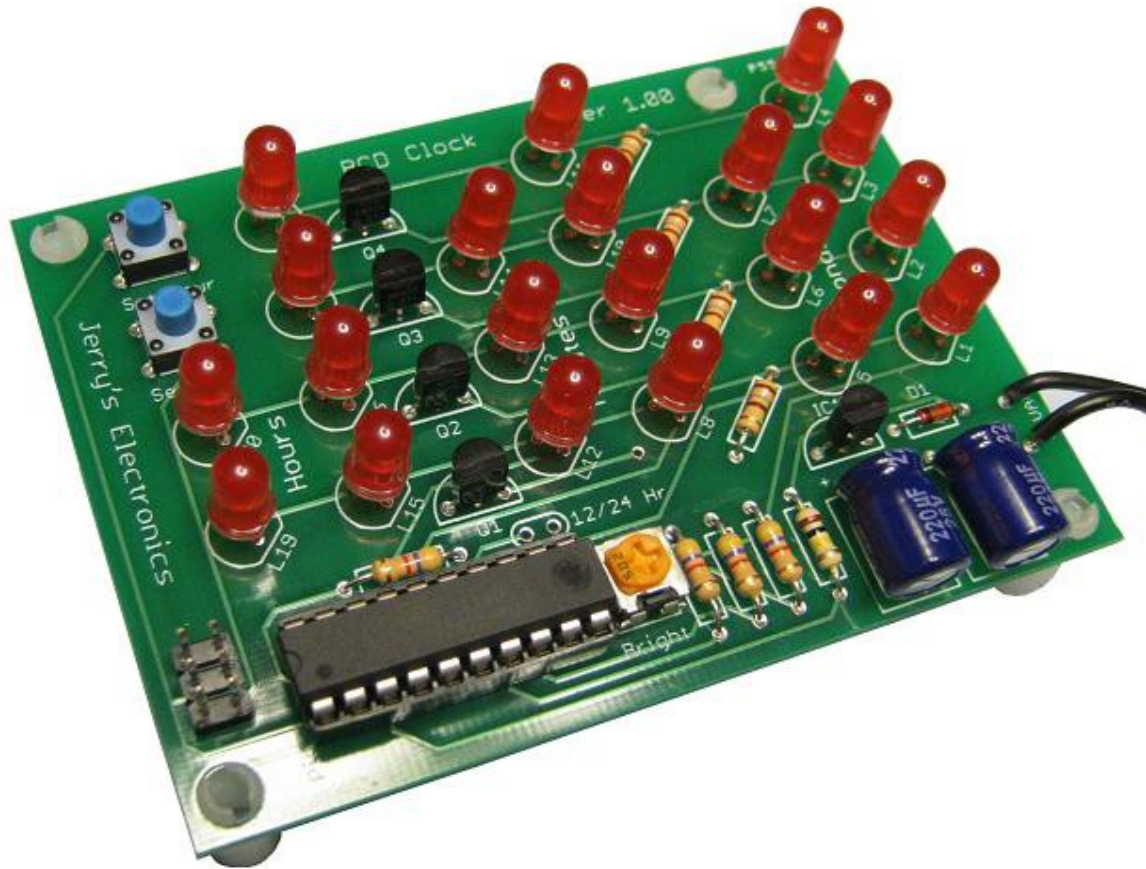

A neat little BCD clock kit features: 12/24 hour time, brightness control, hour and minute set switches. Power requirements are 9 Vac 60 Hz @ 100 ma - wall transformer included, optional red or green LED's or use your own LED's. The brightness and time set switches can be mounted on the rear of the PC board for increased flexibility if you wish to design your own enclosure. The LED's can be set higher off the PC board to facilitate deeper front panels.

What's Included in the kit:

- | | |
|--------------------------------------------------|------------------------------------|
| 1 - Quality PC Board | 1 - Programmed Micro-controller IC |
| 4 - PN2907A Transistors | 1 - LM78L05 Voltage Regulator |
| 2 - 220ufd Electrolytic Capacitors | 1 - 1N914 Diode |
| 20 - Red or Green LED's | 1 - 20 Pin IC Socket |
| 1 - 5K Trimmer Resistor | 2 - Momentary Switches |
| 1 - 100k ¼ Watt Resistors (brown, black, yellow) | 1 - 6 Pin Programming Header |
| 4 - 4.7k ¼ Watt Resistor (yellow, violet, red) | 4 - PCB Standoffs |
| 4 - 180 ohm Resistor (brown, gray, brown) | 1 - Wall Transformer |

What you will need:

1. Good quality soldering iron 25 – 40 watt
2. Solder tip cleaning sponge
3. Rosin core or no clean solder
4. Diagonal wire cutter

Basic instructions:

Insert parts from top side (component side) of PC board.
Parts should be fully inserted, most parts will touch PC board.
If parts are polarity sensitive, double check your installation.
On some parts you can bend the leads after inserting to help hold them in place.
While soldering apply a small amount of solder to the solder tip to help with heat transfer.
Touch the soldering tip to both the component lead and PC board.
To improve your solder connection apply solder to part/PC board instead of solder tip.
The solder should flow around the component lead and on the PC board.
Avoid adding too much solder or too much heat.
Your solder connection should be shiny and smooth, not balled or grainy looking.
If your solder connection is grainy looking try adding some flux and reheat the joint.
Cold solder connections are the most common beginner mistakes.
Cold solder joints happen when the part lead and/or the PC board are not heated well.
After soldering trim the component leads close to the solder joint.

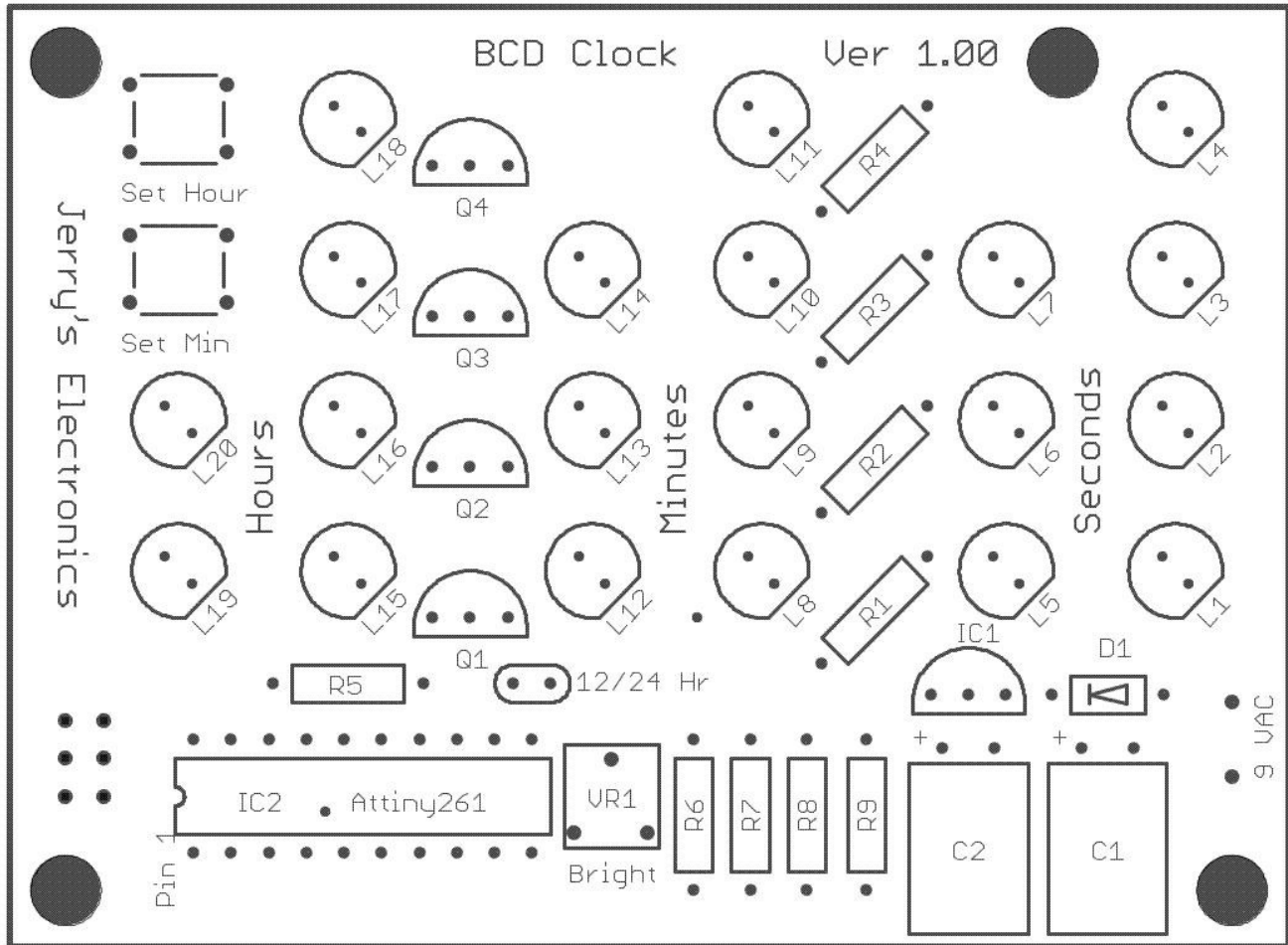

To ease assembly install parts in the following order:

1. R1,2,3,4 – 180 ohm Resistor (brown, gray, brown)
2. R5,6,7,8 – 4.7K Resistor (yellow, violet, red)
3. R9 – 100K Resistor (brown, black, yellow)
4. D1 – 1N914 Diode (observe polarity)
5. 20 Pin IC Socket in IC2 location (observe orientation)
6. VR1 - Trimmer Resistor
7. SW1,2 – Time Set Momentary Switches
8. IC1 – LM78L05 Voltage Regulator (observe orientation)
9. Q1,2,3,4 PN2907A Transistors (observe orientation)
10. C1,2 – 220ufd 25v Electrolytic Capacitors (observe polarity) lay down installation
11. Programming Header - *see tips
12. L1 thru L20 – LED's (observe polarity) - *see tips
13. 9 VAC – Wall Transformer Wires
14. IC2 – ATTiny261A Programmed Micro-controller IC (observe orientation)
15. PCB Standoffs – these can be tough at times to install, you can enlarge the holes slightly by filing

Assembly Tips:

- Clean solder tip with sponge before each solder connection – not after, solder should be balled on end of iron when not using, this increases the soldering tip life.
- Not everyone has a ESD Protected Area, here are some basic tips to follow:
 - a: Do not assemble kit on a carpeted work surface.
 - b: Do not assemble kit in low humidity environment (<40% RH = increased risk).
 - c: Avoid working/walking in carpeted areas.
- Insert components from topside of PC board then turn board over and lay it flat on your work surface to help hold the parts in place while soldering.
- LED's - Insert a row of LED's at a time they will stop a few mm from the board, solder one leg on each LED then examine LED alignment and move the LED's until they are aligned then solder the remaining legs.
- Install programming header only if you plan on reprogramming the micro.
- Install a jumper wire in the 12/24 Hr holes if you desire 24 hour operation.

Schematic:

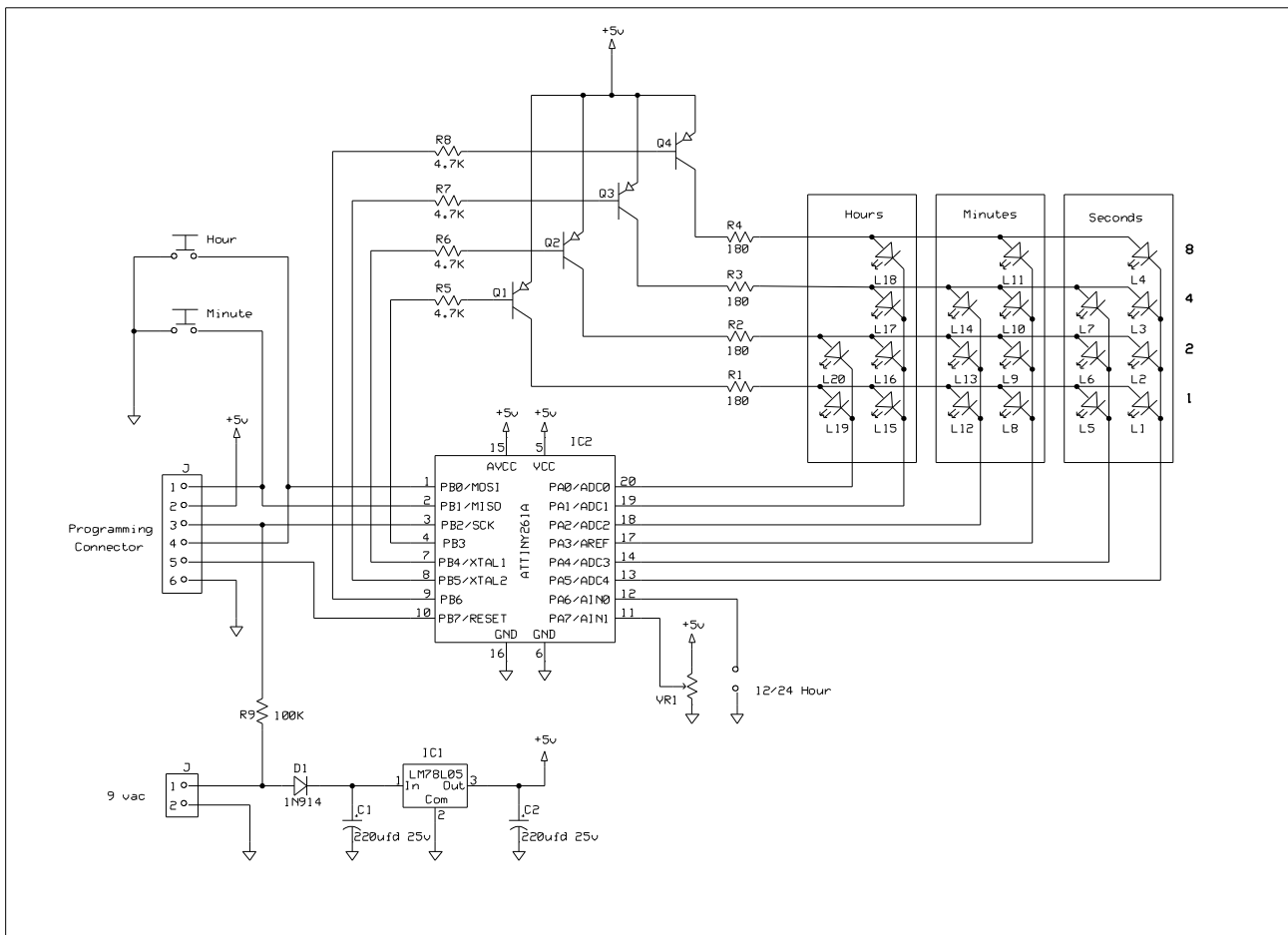

Parts Identification:

LED's
Flat side indicates Cathode
or negative lead

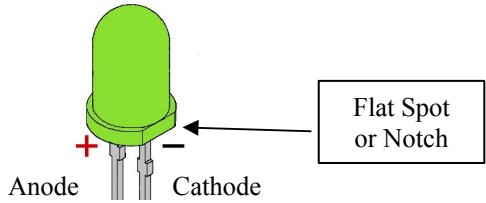

Aluminum Electrolytic Capacitors

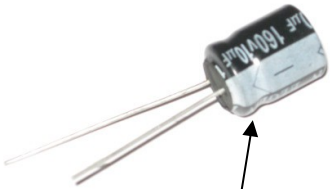

The (-) sign on this white stripe indicates the negative lead, the stripe can be any color.

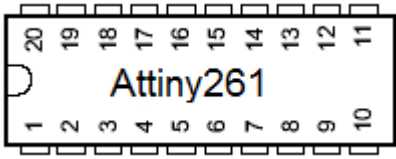

ATTiny261A
Top View

1N914 Diode

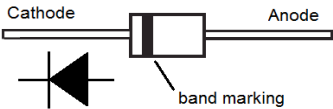

TO-92 (Plastic)

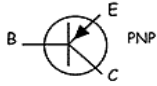
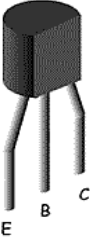

PN2907A
Transistor

LM78L05
5 Volt Reg

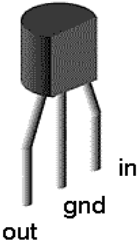

Setting the time:

Set the minutes first in case you over run the desired time, the time will begin advancing after holding the button down for a second, and continue to advance at approximately 0.5 second intervals, release button once desired time is displayed, it might take a little practice at first but it's not difficult, now set the hours.